

AIRconnect – **coax adapter (FME-N)**
AIRconnect – **Koaxadapter (FME-N)**

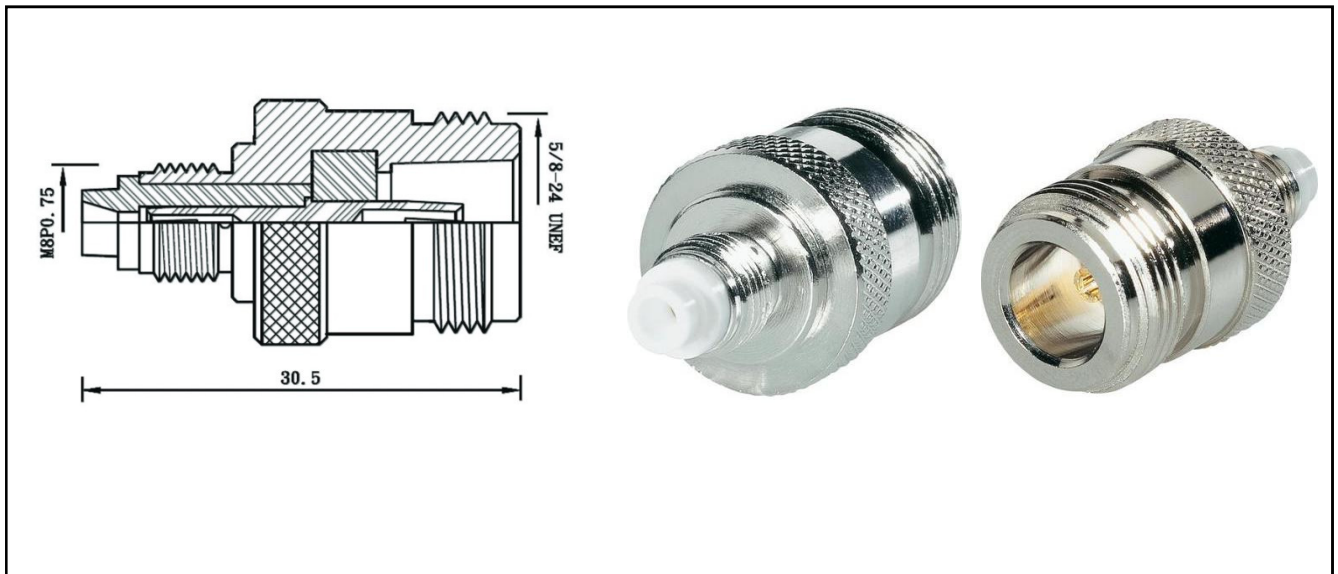

Part – Number 52 40 120
Artikel – Nummer 52 40 120

Type AD-FME-N-120
Typ AD-FME-N-120

Description coax adapter FME to N, straight
Bezeichnung Koaxadapter FME auf N, gerade

Specification coax adapter FME (female) to N (female)
Beschreibung Koaxadapter FME-Buchse auf N-Buchse

Material	housing	brass
Werkstoff	<i>Gehäuse</i>	<i>Messing</i>
	surface	Nickel over copper strike
	<i>Oberfläche</i>	<i>Nickel über Kupferschicht</i>
	contacts	gold over brass (1-3 µm)
	<i>Kontakte</i>	<i>Messing vergoldet (1-3 µm)</i>
	insulator	Delrin (white)
	<i>Isolator</i>	<i>Delrin (weiß)</i>

General Data	characteristic impedance	50 Ω
Allgemeine Daten	<i>Wellenwiderstand</i>	<i>50 Ω</i>
	Connector interface	per MIL-STD-348A
	<i>Schnittstellenanschluss</i>	<i>nach MIL-STD-348A</i>
	tightening torque	max. 1,7 Nm
	<i>Anzugsdrehmoment</i>	<i>max. 1,7 Nm</i>

Weight approx. 25 g
Gewicht ca. 25 g