

AIRtronic – Grounding latches, stainless steel with thread

AIRtronic – Edelstahl-Erdungslasche mit Gewinde

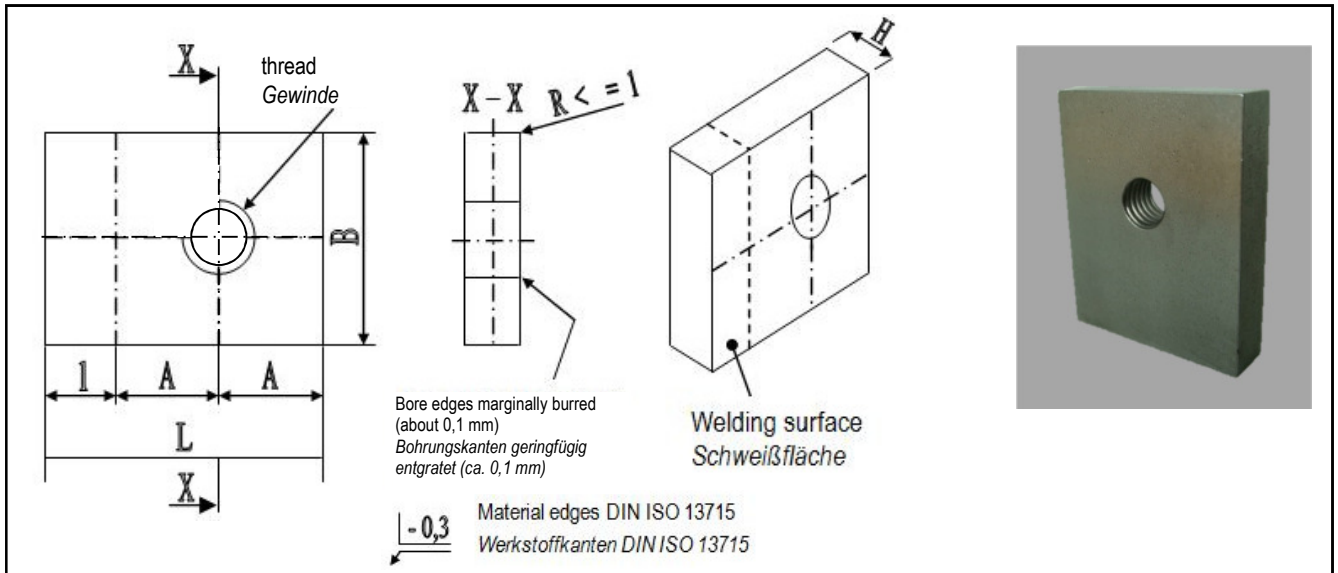

Description Grounding latch, 1.4301, thread
Bezeichnung Erdungslasche, 1.4301, Gewinde

Specification Grounding latch with thread for welding
Beschreibung Erdungslasche mit Gewinde zum Anschweißen

Material X5CrNi 18 10 1.4301 blank DIN 174
 EN1088
 Drawn basic material

Werkstoff X5CrNi 18 10 1.4301 blank DIN 174
 EN 10088
 Basismaterial gezogen

thread Gewinde	Part No. Artikel-Nr.	Dimensions [mm] Abmessungen [mm]					Weight (g) Gewicht (g)	Type Typ	max. tightening torque (Nm)* max. Anzugsdrehmoment (Nm)*
		A	B	H	L	I			
M 5	11 00 710	12	30	5	30	6	30	ERL-M5 - 710	3,7
M 6	11 00 711	12	30	5	30	6	30	ERL-M6 - 711	6,5
M 8	11 00 712	15	30	10	40	10	84	ERL-M8 - 712	15,0
M 10	11 00 713	20	40	10	50	10	146	ERL-M10-713	31,0
M 12	11 00 714	20	40	10	50	10	140	ERL-M12-714	53,0

* screw strength class 5.8
 * Schraubenfestigkeitsklasse 5.8.